

# M4-ATX

## 6-30V Intelligent ATX Power Supply

### Installation Guide

Version 1.0c  
P/N M4-ATX-01

#### Before you start...

Please take a moment and read this manual before you install the M4-ATX in your vehicle. Often times, rushing into installing the unit can result in serious damage to your M4-ATX board, computer and probably your car's electrical system. **Always double check the polarity** of your wires with a voltmeter.

Avoid using the cigarette plug as a power source, often times the contacts are not capable of delivering high current to your PC.

#### Introduction

Thank you for purchasing the M4-ATX power sequencer / vehicle ATX power supply.

The M4-ATX was designed to work with a wide variety of main boards ranging from low power to fully fledged Intel, AMD or VIA models .

#### M4-ATX Logic Diagram

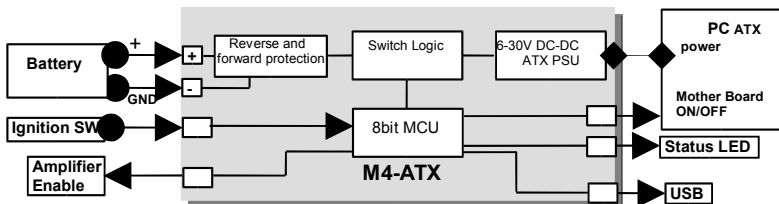

### 1.2 M4-ATX Connection diagram

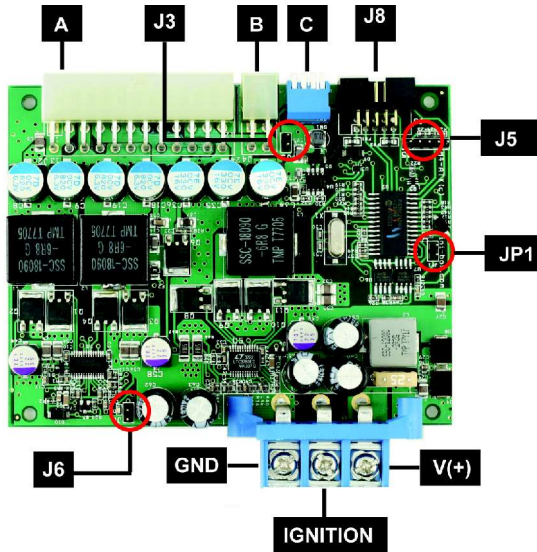

**Power Input Connectors (bottom, right side)**

- Left     **Battery negative (GND)**
- Center   **Ignition (switched battery, positive. Can test by connecting it to Battery +)**
- Right    **Battery positive (+)**

- (A) ATX Power Output Connector 20/24 pin connector
- (B) 12V-ATX power output connector 4 pin
- (C) Configuration dip switch

- (J5) For internal use only (do not use)
- (J6) Amplifier THUMP wire harness (connects to the M4-ATX pin header)
- (J3) Fan Header
- (J8) USB, Motherboard ON/OFF and THUMP (Thump also available on J6)

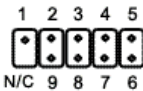

- 1) +5V
- 2) USB D-
- 3) USB D+
- 4) GND
- 5) GND
- 6) To Motherboard ON/OFF
- 7) To motherboard ON/OFF
- 8) Amplifier Thump
- 9) GND
- 19) N/C (key)

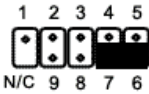

**J8 shown with cable harness connected to the motherboard ON-OFF header (pin 7 and 6)**

DIP Switch (ON=down)				Off-delay (All rails ON)	Hard-off (5VSB)
1	2	3	P		
OFF	OFF	OFF	<b>P0</b>	Standard	PSU mode
ON	OFF	OFF	<b>P1</b>	5sec	1 min
OFF	ON	OFF	<b>P2</b>	5sec	1 hour
ON	ON	OFF	<b>P3</b>	5sec	<b>NEVER</b>
OFF	OFF	ON	<b>P4</b>	30sec	1 hour
ON	OFF	ON	<b>P5</b>	30sec	<b>NEVER</b>
OFF	ON	ON	<b>P6</b>	30min	<b>NEVER</b>
ON	ON	ON	<b>P7</b>	3hour	<b>NEVER</b>

**IMPORTANT:** Always use the “Hibernate” feature on your PC, never use “Standby”.

**NEVER** use “hard-off = NEVER” settings unless you fully understand the risks of battery depletion. Even with safety limits in place, your car battery might be not be able to start your engine.

**P0:** In this mode, the M4-ATX behaves like a regular ATX power supply.

**P1 (recommended):** Sends ON pulse to motherboard when ignition is ON for more than 2 seconds, sends OFF pulse to motherboard **5 seconds** after ignition is turned off. Waits another **1 minute** and then shuts down 5VSB to conserve battery. In this mode, the M4-ATX consumes less than 0.5mA. **This is our recommended setting.**

**P1 (recommended):** Sends ON pulse to

**NOTE:** To reset to the M4-ATX settings to the factory defaults (in case changes were made via the USB uplink), simply power off the unit, connect a jumper to JP1 and then power back up. The LED light will start to flash rapidly indicating that the factory defaults were loaded. **Don’t forget to Remove jumper when done!** Disconnect M4-ATX from battery for at least 10 seconds. Next time when power is applied, M4-ATX will operate from the factory defaults settings.

**Power challenges in a Vehicle PC:** One of most difficult tasks of operating a PC in a vehicle is power consumption while the computer is OFF. Even when your computer is OFF, it will still consume about 100mA on the 5V rail. When the computer is in the suspend mode, it will consume even more power, because the RAM needs to be powered at all times. *No matter how big your battery is, you will eventually drain it if proper actions are not taken.*

The M4-ATX is addressing these issues by cutting off the 5VSB rail after a pre-defined amount of time (see jumper chart, HARDOFF). During the HARDOFF if the battery level drops below 11.2V for more than one minute, M4-ATX will shut down and re-activate only when the input voltage is > 12V.

**Engine Cranks, under-voltage and over-voltage situations.** Another difficult task is maintaining stable power to your PC. While car batteries are rated at 12V, they actually provide voltages in between 7-11V (engine cranks) or as high as 80 volts (load dump). Most of the times, your battery will stay at 13.5V (while car is running) but extra precautions need to take place in order to prevent such situations. M4-ATX can operate as low as 6V and as high as 30V while providing strict regulation on all rails along with input voltage clamping and reverse protection.

**Loud amplifier pops when PC starts.** If your PC is connected to your car amplifier, you will hear a loud pop when the computer is first started. The M4-ATX has an 'anti-thump' control that will keep your amp OFF while the PC starts. Simply connect the white wire from your M4-ATX cable harness to your amplifier remote control pin.

**Mode of operation**

- 1) Ignition=OFF. Nothing happens. M4-ATX is waiting for ignition signals.
- 2) Ignition=ON. M4-ATX waits for 2-3 seconds then turns on the 5VSB rail. After another second M4-ATX sends an "ON" signal to the motherboard via the 2 wires connected to the motherboard's ON/OFF pins. The motherboard will turn ON and your system should start booting.
- 3) Ignition=ON. Your computer will remain ON.
- 4) Ignition=OFF. M4-ATX waits for "OFFDELAY" in seconds (see jumper chart) and then it turns the motherboard OFF by sending a signal to the motherboard's ON/OFF switch. Your computer should turn off gracefully (shutdown procedure). After shutdown, 5VSB will still be provided for another "HARDOFF" seconds. In the event where the shutdown process is longer than "HARDOFF" (Operating System gets frozen, etc), power will be shut down hard, turning off all power rails. During the HARDOFF procedure, the battery levels will be constantly monitored to prevent deep discharge situations.
- 5) M4-ATX will go to step 1, if ignition is tuned ON again.

**NOTE.** When all dip switches are off, M4-ATX acts as a regular power supply, no ignition timing, no HARDOFF. M4-ATX will send a gratuitous "ON" pulse to the M/B when power is applied for the first time. Do not connect the on/off switch if you don't want your PC to be started automatically.

**M4-ATX Characteristics**

Minimum Input Operating voltage	6V
Maximum input Operating voltage	30V (hard clamping will occur at 34V)
Deep-Discharge shutdown threshold	11.2V
Input current limit (fuse protected)	Mini-blade 25A
Max Output Power	250 Watts / 300 watts peak
Deep Sleep Current Consumption.	< 1.6mA
Storage and operating temperature	-40 to +125 degrees Celsius (storage), -40 – 65C (operating)
MTBF	200,000 Hrs
Efficiency (Input 9-16V)	>95%, all rails combined, 50% load.
Input connectors	M4 screw terminal
Output Connector	ATX Power 24 pin (Molex P/N 39-01-2200)

\*Unit shuts down when internal temperature sensor indicates > 85C. This value can be changed with software.

**Maximum Power Characteristics**

Output Rail	Current (Max)	Current Peak (<30 seconds)	Regulation
5V	15A	20A	1.5%
3.3V	15A	20A	1.5%
5VSB	1.5A	2A	1.5%
-12V	0.15A	0.2A	10%
12V	10A (see below)	16A (see below)	2%

When operating at <8V or >28V or extreme temperatures, de-rate by 25%, ventilation might be required. When operating at constant 160watts or more forced ventilation might be required.

**12V Rail Output Current (12V buck/boost converter)**

Input (V)	12V out current	Input (V)	12V out current
6-8V	8A (10A peak)	11-16V	12A (16A peak)
8-11V	10A (12A peak)	16-30V	12A (14A peak)

**Support and warranty:** Standard Hardware Warranty 1Year / US, 2 Year EU

